

Welcome to the Accessibility Online Webinar Series



A collaborative program between
the
ADA National Network and the
US Access Board



**The Session is Scheduled to begin at 2:30pm Eastern Standard Time
We will be testing sound quality periodically**

Audio and Visual are provided through the on-line webinar system. This session is closed captioned. Individuals may also listen via telephone by dialing 712 432 3100 code 930098 # (This is **not** a Toll Free number)

The content and materials of this training are property of the US Access Board and the DBTAC - Great Lakes ADA Center and cannot be used and/or distributed without permission. This program is funded under award #H133A060097 from the U.S. Department of Education through the auspices of the National Institute on Disability and Rehabilitation Research (NIDRR) and an inter-agency agreement with the U.S. Access Board. For permission to use training content or obtain copies of materials used as part of this program please contact us by email at adata@adagreatlakes.org or toll free (877)232-1990 (V/TTY)

www.AccessibilityOnline.org

1



Webinar Features



- **Closed captioning** – click **CC** icon (top of screen) or control-F8 and adjust your screen
- **Questions** - type and submit questions in the Chat Area Text box or press control-M and enter text in the Chat Area
- Please do not use emoticons or hand-raising features during this session

2



Enforcing the Architectural Barriers Act (ABA): Making Federally-Funded Buildings Accessible

3

Presenters U.S. Access Board



Peg Blechman Compliance Specialist



Jeffery Hill Senior Compliance Specialist

4



Session Agenda

- Legal Authority
- ABA-Covered Facilities
- Most Common Barriers to Accessibility
- ABA Complaints
- ABA Complaint Investigation Process
- Q & A

UNITED STATES ACCESS BOARD

5

Legal Authority



- The Architectural Barriers Act of 1968
- Section 502 of the Rehabilitation Act of 1973
- 36 Code of Federal Regulations Part 1150

UNITED STATES ACCESS BOARD

6



Legal Authority

Architectural Barriers Act (ABA) of 1968, as amended

Requires that **facilities** which are:

- (a) **designed, built or altered** by or on behalf of the United States,
- (b) **leased**, in whole or in part by the United States, or
- (c) **financed** in whole or in part by a grant or loan made by the United States after August 12, 1968

BE ACCESSIBLE TO PERSONS WITH DISABILITIES.

UNITED STATES ACCESS BOARD

7



Legal Authority

Section 502 of The Rehabilitation Act of 1973

- **Authorizes the Access Board** to ensure that buildings financed with certain Federal funds are in compliance with the ABA by:
 1. **Establishing and maintaining minimum guidelines** for standards issued by GSA, DoD, HUD and USPS; and
 2. **Enforcing the ABA** by investigating complaints concerning particular facilities.

UNITED STATES ACCESS BOARD

8



Legal Authority

36 Code of Federal Regulations (CFR) Part 1150

- contains enforcement procedures related to the ABA

ABA-Covered Facilities

- Federal and non-Federal Buildings;
- Newly-constructed,
- Altered or
- Leased
- after 1968

ABA-Covered Facilities

Federal Examples:

- Federal office buildings
- Social Security offices
- National parks
- United States Post Offices
- Federal prisons
- Federal courthouses



UNITED STATES ACCESS BOARD

11

ABA-Covered Facilities

Non-Federal Examples:

“Financed in whole or in part by a grant or loan made by the United States”

- Certain Schools
- Certain Mass Transit Stations
- County Courthouses and Jails
- Public Housing

UNITED STATES ACCESS BOARD

12

ABA-Covered Facilities

While Federal facilities built before 1968
are not covered,

alterations and leases

- undertaken after 1968
can trigger ABA coverage

Most Common Barriers to Accessibility

- Accessible Routes
- Accessible Parking
- Entrances
- Interior Doors
- Toilet Rooms

Accessible Route Width



UNITED STATES ACCESS BOARD

15

Accessible Route Cross Slope



UNITED STATES ACCESS BOARD

16

Accessible Route Surface



UNITED STATES ACCESS BOARD

17

Accessible Route Curb Ramp



UNITED STATES ACCESS BOARD

18

Accessible Parking Required Number of Accessible Parking Spaces

Total Number of Parking Spaces Provided in Parking Facility	Minimum Number of Required Accessible Parking Spaces
1 to 25	1
26 to 50	2
51 to 75	3
76 to 100	4
101 to 150	5
151 to 200	6
201 to 300	7
301 to 400	8
401 to 500	9
501 to 1000	<u>2 percent of total</u>
1001 and over	<u>20, plus 1 for each 100, or fraction thereof, over 1000</u>

UNITED STATES ACCESS BOARD

19

Accessible Parking Located Closest to the Accessible Entrance



UNITED STATES ACCESS BOARD

20

Accessible Parking

Level Access Aisle



UNITED STATES ACCESS BOARD

21

Accessible Parking

Dimensions of Accessible Parking Spaces

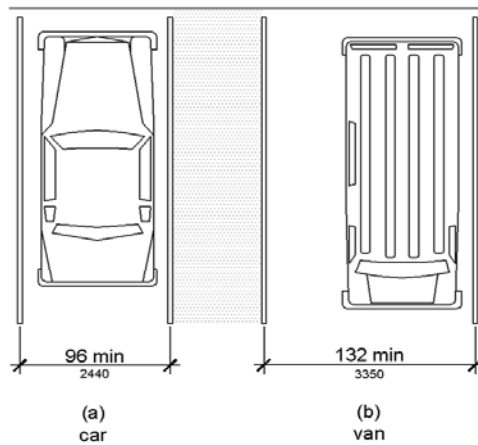

UNITED STATES ACCESS BOARD

22

Accessible Parking Adjacent Access Aisle

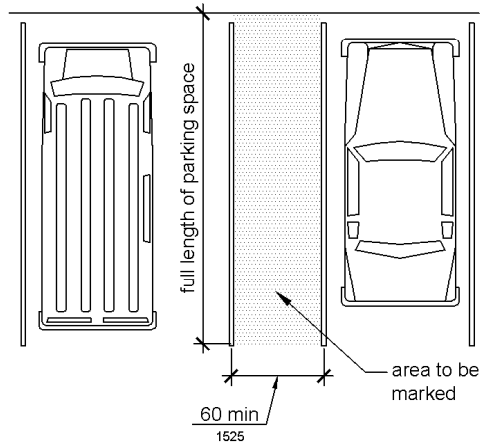

UNITED STATES ACCESS BOARD

23

Accessible Parking Level Accessible Parking Space



UNITED STATES ACCESS BOARD

24

Entrances

Inaccessible Entrance due to Steps



UNITED STATES ACCESS BOARD

25

Entrances Maneuvering Clearance

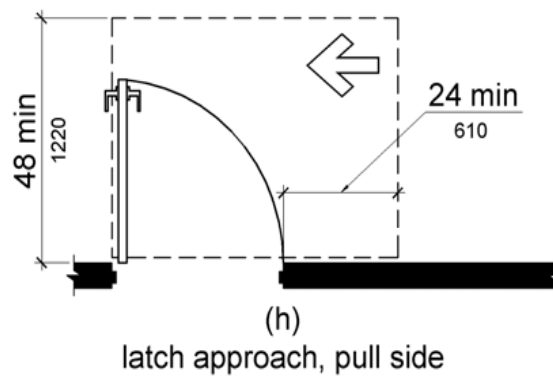

UNITED STATES ACCESS BOARD

26

Interior Doors Heavy Interior Doors



UNITED STATES ACCESS BOARD

27

Interior Doors Distance between Two Doors in Series

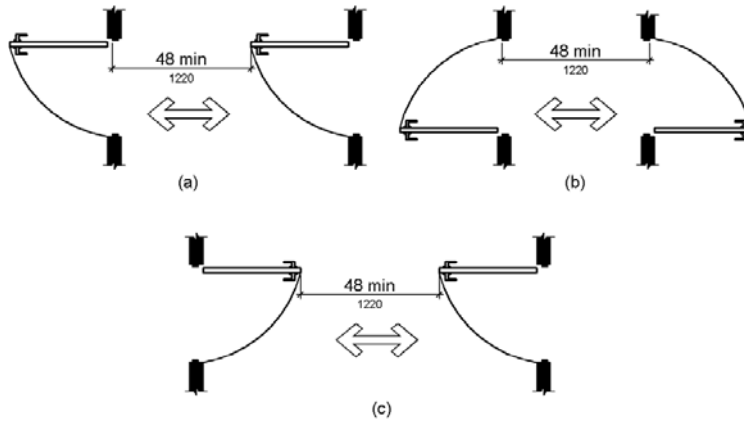

UNITED STATES ACCESS BOARD

28

Toilet Rooms

Dispenser out of Reach Range



UNITED STATES ACCESS BOARD

29

Toilet Rooms

Turning Space and Dimensions

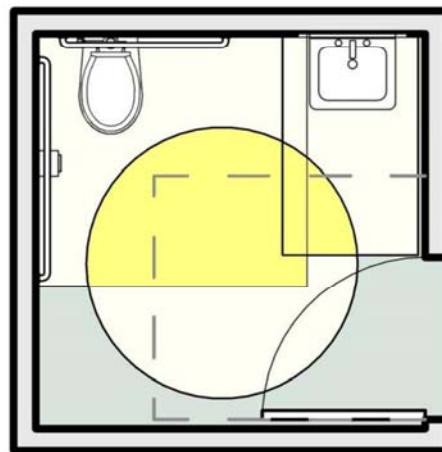

UNITED STATES ACCESS BOARD

30

ABA Complaints

- Who Can Initiate an ABA Complaint?
- How Do You Initiate an ABA Complaint?
- Facility Types FY03-FY07
- Barriers to Accessibility FY04-FY08
- ABA Complaint Investigation Process
- Written ABA Complaint

ABA Complaints

Who can Initiate an ABA complaint?

Anyone You do not need to have a disability

ABA Complaints

How do you initiate an ABA Complaint?

When a Complainant sends the Access Board a written complaint

ABA Complaints Facility Types FY03-FY07

Facility Types	Percentage
United States Post Offices	63
Office Buildings/Suites	10
Recreational	9
Educational	4
Health Care	3
State/Local Government	3
Courthouses & Other Judicial	2
Other	6
TOTAL	100%

ABA Complaints Barriers to Accessibility FY04-FY08

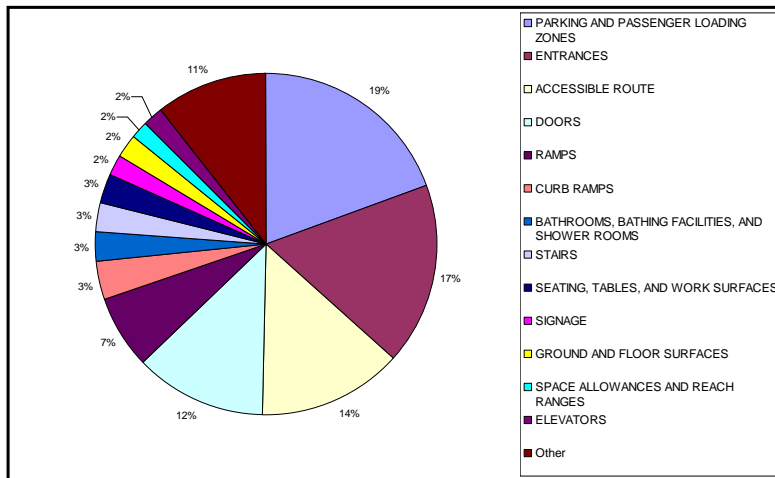

UNITED STATES ACCESS BOARD

35

ABA Complaints

ABA Complaint must be in writing:

No special form is required, but

– Template on-line at
www.access-board.gov/enforce.htm

– Email: enforce@access-board.gov

– or in the Access Board brochure:

**“About the Architectural Barriers Act
and Other Disability Rights Laws”**

UNITED STATES ACCESS BOARD

36

ABA Complaints

Written ABA Complaint Must Contain:

- Facility name and address;
- brief description of each of the barriers to accessibility;

UNITED STATES ACCESS BOARD

37

ABA Complaints

A Complaint may contain:

Complainant's name, address, phone number

- **Access Board will not disclose Complainant's identity**
- A Complaint also may be filed anonymously

UNITED STATES ACCESS BOARD

38

ABA Complaints

Who at Access Board handles complaints?

- Compliance Specialists, Enforcement Section, Office of General Counsel

ABA Complaint Investigation Process

Step 1

- Preliminary Analysis

Step 2

- Complaint Investigation

Step 3

- Covered by the ABA?

ABA Complaint Investigation Process

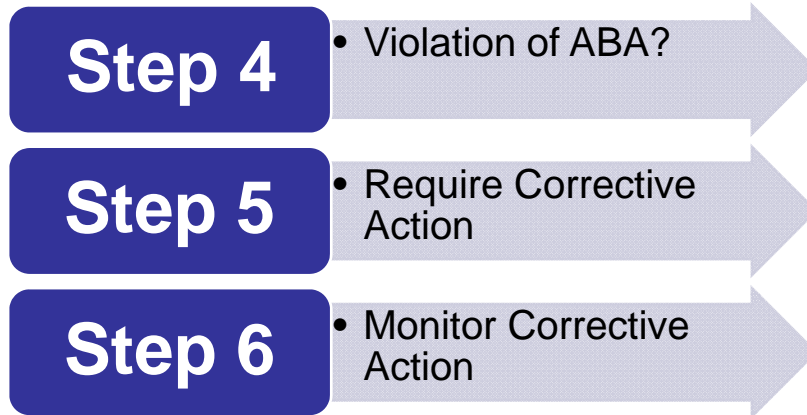

UNITED STATES ACCESS BOARD

41

ABA Complaint Investigation Process



UNITED STATES ACCESS BOARD

42

Step 1

Preliminary Analysis

- From the facts of the Complaint:
- Could the facility be covered by the ABA?

UNITED STATES ACCESS BOARD

43

Step 1

Preliminary Analysis

- If facility could be covered by the ABA,
- Open a Complaint investigation
- Send the Complainant an Acknowledgement Letter

UNITED STATES ACCESS BOARD

44

Step 1

Preliminary Analysis

- If facility could not be covered by the ABA,
- Do not open a Complaint
- Send the Complainant a letter explaining our findings

UNITED STATES ACCESS BOARD

45

Step 2

Complaint Investigation

- Identify appropriate Federal agency
- Send Agency Letter of Inquiry and Complaint allegations
- Receive from Agency: Facility questionnaire

UNITED STATES ACCESS BOARD

46

Step 3

**Covered by
the ABA?**

Three pronged test –

Was this facility:

1. designed, built or altered by or on behalf of the United States
2. Leased in whole or in part by the United States, or
3. Financed in whole or in part by a grant or loan made by the United States after August 12, 1968?)

UNITED STATES ACCESS BOARD

47

Step 4

**Violation
of the
ABA?**

- Is the alleged accessibility barrier inconsistent with the ABA?

UNITED STATES ACCESS BOARD

48

Step 4

Violation of the ABA?

Review -
 The accessibility barriers as stated in the complaint,
 The applicable ABA requirements, Photographs, architectural drawings, other relevant materials,
 And consult, as necessary, with other Board staff

Step 4. Violation of the ABA? Applicable ABA Requirements

Standard Setting Agencies	Current Requirements
	Architectural Barriers Act Accessibility Standards (ABAAS)
DOD	October 2008
GSA	May 2006
USPS	October 2005
	Uniform Federal Accessibility Standards (UFAS)
HUD	November 1984

Step 5

Require Corrective Action

- Once determine that there is an ABA Violation:
- Require the Agency take Corrective Action

UNITED STATES ACCESS BOARD

51

Step 6

Monitor Corrective Action

- **CORRECTIVE ACTION:**
- Agency must submit plan
- based on the applicable ABA requirements

UNITED STATES ACCESS BOARD

52

Step 6

Monitor Corrective Action

- **VOLUNTARY CORRECTIVE ACTION:**
- Some agencies agree to take voluntary corrective action to remove an accessibility barrier

UNITED STATES ACCESS BOARD

53

Step 6

Monitor Corrective Action

- **Review Corrective Action Plan**

UNITED STATES ACCESS BOARD

54

Step 6

Monitor Corrective Action

- Approve Corrective Action Plan
- Notify in writing:
 - Complainant
 - Agency

UNITED STATES ACCESS BOARD

55

Step 6

Monitor Corrective Action

- Monitor by:
 - email updates
 - architectural or dimensioned drawings
 - photographs

UNITED STATES ACCESS BOARD

56

Step 6

Monitor Corrective Action

- Agency verifies:
- Corrective Action
 - Completed
 - and meets applicable ABA requirements

UNITED STATES ACCESS BOARD

57

Step 7

Close the Complaint

- Compliance Specialist -
- notifies Complainant in writing of the completed Corrective Action
- and gives the Complainant 15 days to respond.

UNITED STATES ACCESS BOARD

58

Step 7

If Complainant does not provide contradictory information



Compliance Specialist notifies the Agency that Complaint is closed.

Step 7

Close the Complaint

- When Compliance Specialist determines
 - Facility not covered by the ABA
 - Or no violation of ABA requirements
- notifies Complainant

Step 7

If Compliance Specialist believes that another accessibility law may apply



Provides the complainant with:

- Potentially applicable accessibility law(s)
- and enforcing Agency contact information

Step 7

Close the Complaint

- Compliance Specialist will not forward a Complaint directly to another Agency
- Access Board regulations require that we do not disclose Complainant's identity to ensure protection of privacy

Complaint: Example 1

A Federal facility

– with no accessible parking

- **Investigation reveals that the parking is**
 - On-street parking**
 - Controlled by the local government**

UNITED STATES ACCESS BOARD

63

Complaint: Example 2

A Federal facility

– with an inaccessible entrance due to steps

- **Investigation reveals that the facility**
 - Built before 1968**
 - Entrance and entrance steps not altered since 1968**

UNITED STATES ACCESS BOARD

64

How to File an ABA Complaint

Send a complaint **in writing** to the Access Board:

– by mail:

**U.S. Access Board
1331 F Street, NW, Suite 1000
Washington, DC 20004-1111**

– by email: enforce@access-board.gov

– by fax: **(202) 272-0081**

UNITED STATES ACCESS BOARD

65

How to File an ABA Complaint

No special form is required, but

- On-line: www.access-board.gov/enforce.htm

- or in the Access Board brochure:



- **“About the Architectural Barriers Act and Other Disability Rights Laws”**

66

Written ABA Complaint Example

Your Name: John Smith

Address: 2222 Any Street,
Any Town, Any State 22222

Daytime phone: 222-222-2222

UNITED STATES ACCESS BOARD

67

Written ABA Complaint

If provided, we will protect the
Complainant's identity

- It is optional, but helpful.
- so that we can contact you with any questions
- Complaints may also be filed anonymously.

UNITED STATES ACCESS BOARD

68

Written ABA Complaint

Example

Building or Facility: John Doe Federal Building

Address: 11 Any Street Any City, Any State 11111

Phone number: 111-111-1111

UNITED STATES ACCESS BOARD

69

Written ABA Complaint

Precise description of each barrier:

Examples:

- the entrance is inaccessible;
 - there are steps to the entrance;
- there are no accessible parking spaces;
- and the interior doors are heavy.

UNITED STATES ACCESS BOARD

70

Other ABA Complaint Resources

On Access Board website at:

www.access-board.gov/enforce.htm

UNITED STATES ACCESS BOARD

71

Access Board Information

Website: www.access-board.gov

Phone numbers:

(202) 272-0080 (V)

(202) 272-0082 (TTY)

(202) 272-0081 (FAX)

(800) 872-2253 (V)

(800) 993-2822 (TTY)

UNITED STATES ACCESS BOARD

72

Access Board Information

Peg Blechman, Compliance Specialist

blechman@access-board.gov

Jeff Hill, Senior Compliance Specialist

hill@access-board.gov

UNITED STATES ACCESS BOARD

73

Questions?

You May Type and Submit
questions in the Chat Area Text
Box or press Control-M and enter
text in the Chat Area

UNITED STATES ACCESS BOARD

74

**Thank you for participating
in today's webinar**



Next scheduled session:

***“Open Question and Answer Session with Access
Board Accessibility Specialists”***

May 5th, 2011

www.accessibilityonline.org 877-232-1990 (V/TTY)

75